

C. Anderson,

Plating Iron.

No. 112,105.

Patented Feb. 28. 1871

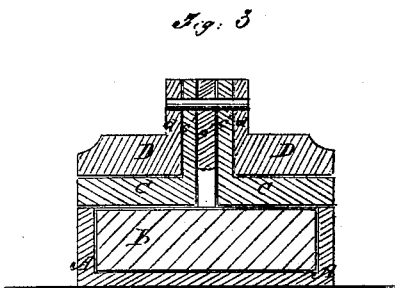
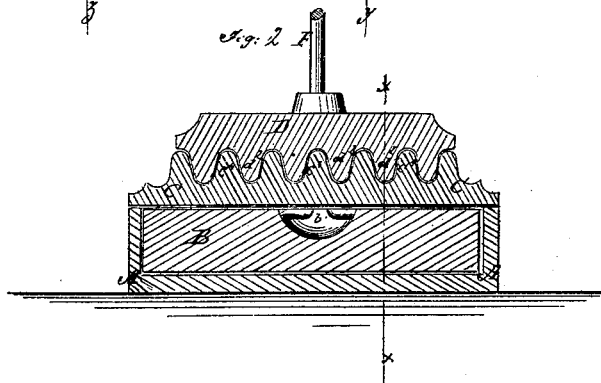
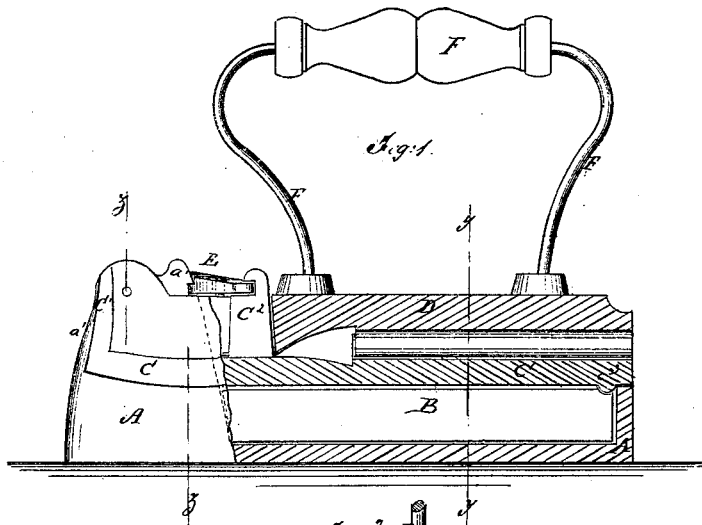

Witnesses:
Chas. Nida.
Wm H. C. Smith.

Inventor:
Chas. Anderson.

PER *Munn Ho*
Attorneys.

UNITED STATES PATENT OFFICE.

CHARLES ANDERSON, OF MONTANA, IOWA.

IMPROVEMENT IN SAD AND CRIMPING IRONS.

Specification forming part of Letters Patent No. **112,105**, dated February 28, 1871.

To all whom it may concern:

Be it known that I, CHARLES ANDERSON, of Montana, in the county of Boone and State of Iowa, have invented a new and useful Improvement in Combined Crimping and Sad Iron; and I do hereby declare that the following is a full, clear, and exact description thereof, which will enable others skilled in the art to make and use the same, reference being had to the accompanying drawing, forming part of this specification, in which—

Figure 1 is a side view of my improved crimping and sad iron, partly in section through the line *x x*, Fig. 2. Fig. 2 is a vertical cross-section of the same, taken through the line *y y*, Fig. 1. Fig. 3 is a detail sectional view of the same, taken through the line *z z*, Fig. 2.

Similar letters of reference indicate corresponding parts.

My invention has for its object to furnish an improved sad-iron, which shall be simple in construction, conveniently manipulated, and which may be used for crimping or ironing, as may be desired; and it consists in the construction and combination of various parts, as hereinafter more fully described.

A is the lowest part of the iron, the lower surface of which comes in contact with the clothes when the iron is used as a sad or smoothing iron. In the upper side of the part A is formed a deep recess to receive the heating-iron B, which fits into the said recess and heats the iron for use, and keeps it hot while being used. Two of the heaters B are intended to go with each sad-iron, so that one may be in the fire becoming heated while the other is being used.

The heater B has a recess, *b'*, formed in the rear part of its upper side, similar to the recess in a stove-cover, to receive the end of a handle or lifter for convenience in handling it.

Upon the upper side of the forward end of the part A is formed an upwardly-projecting piece, *a'*, in the forward part of the upper end of which is formed a hole to receive the pin by which the parts C and D are pivoted to the part A. Upon the upper part of the rear edge of the projection *a'* is formed a notch to receive the lock-lever or button E.

The lower side of the part C is so formed as

to fit upon the upper sides of the parts A B, and has a projecting piece or part, *c'*, formed upon the upper side of its forward end, which projection *c'* is slotted to receive the projection *a'* of the part A, and has a hole formed through it corresponding in position with the hole in the said projection *a'* to receive the pivoting-pin by which the part C is pivoted to the part A.

Upon the upper side of the forward part of the part C, at a little distance in the rear of the projection *c'*, is formed a second projection, *c''*, which projects upward through a slot in the forward part of the upper part D, and has a notch formed in its forward edge to receive the lock-lever or button E.

Upon the rear part of the lower side of the part C is formed a cross-rib, *c'''*, which fits into a recess or groove formed for it in the part A or part B, or in the space between the rear ends of the parts A and B, to receive the strain when ironing or smoothing clothes, and thus relieve the pivoting-pin from having to sustain the whole of said strain. The rear part of the top of the part C is corrugated longitudinally to form a crimping-plate, *c''''*.

D is the upper part, to which the handle F is attached in the ordinary manner. The forward end of the upper part D is slotted to receive the projection *c''* and the projections *c' a'*, the slotted forward end, *d'*, of the part D projecting upward slightly, and having a hole formed in it to receive the pivoting-pin.

The lower side of the rear part of the part D has corrugations *d''* formed in it to correspond with and fit into the corrugations *c''''* of the part C, as shown in Fig. 2.

The lock-lever or button E is pivoted to the upper side of the forward part of the part D, with its forward end between the forward edge of the projection *c''* and the rear edges of the projections *a' d' c'*. When the forward end of the lever E is between the projection *c''* and the projections *a' c' d'* the rear part of the part D may be raised from the rear part of the part C, so that the machine may be used for crimping. When the lever E is moved into the notch in the forward edge of the projection *c''*, the rear ends of the two parts C D may be raised together to remove and insert the heater B. When the lever E is moved into the notch in

the rear edge of the projection *a'*, the three parts A C D will be securely fastened together, and the machine may be used as a sad-iron.

Having thus described my invention, I claim as new and desire to secure by Letters Patent—

1. The notched projections *a' c'*, the slotted projections *C' d'*, and the lock-lever or button E, said parts being constructed and operating in connection with each other and with the parts A B C, substantially as herein shown and described, and for the purpose set forth.

- 2. An improved combined crimping and sad iron formed by the combination of the three parts A C D, handle F, and heater B with each other, substantially as herein shown and described, and for the purpose set forth.

CHARLES ANDERSON.

Witnesses:

J. A. EATON,

GEO. B. CAMPBELL.